

(No Model.)

3 Sheets—Sheet 1.

J. F. FIFE.

MACHINE FOR CORRUGATING WROUGHT METAL TUBING.

No. 432,232.

Patented July 15, 1890.

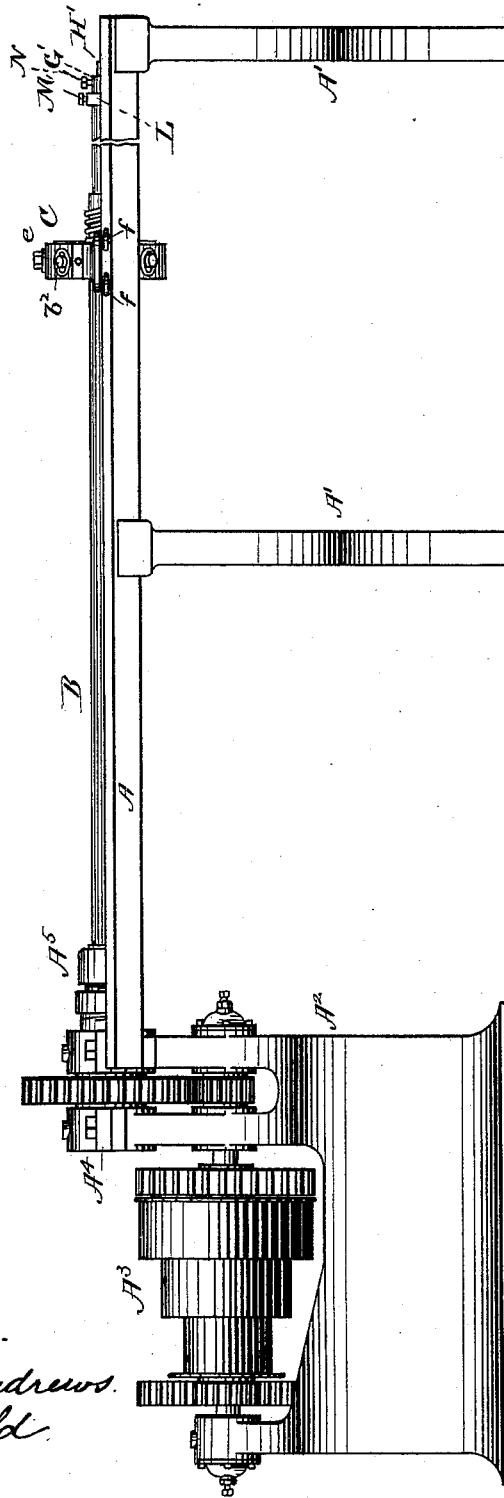

FIG. 1.

WITNESSES.

Hiram B. Andrews.
Eva A. Guild.

INVENTOR.

John F. Fife
By Geo. O. G. Bone
Attorney

J. F. FIFE.

MACHINE FOR CORRUGATING WROUGHT METAL TUBING.

No. 432,232.

Patented July 15, 1890.

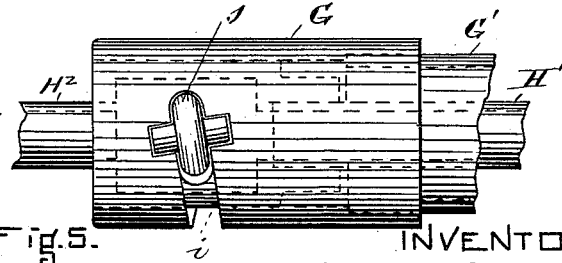
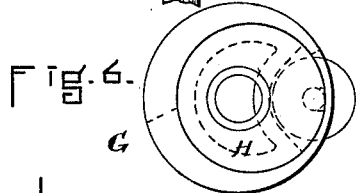
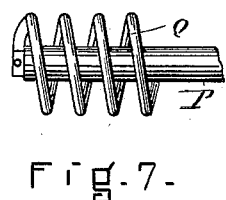
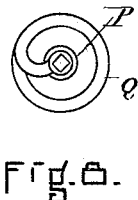
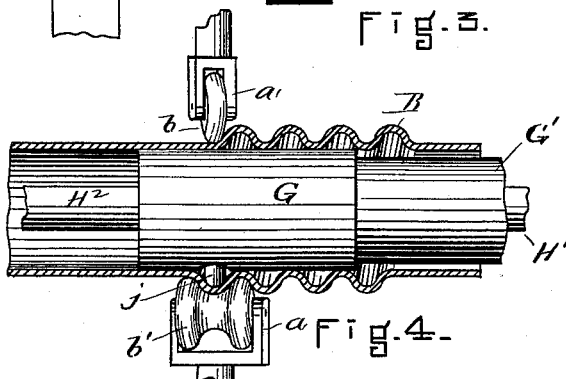
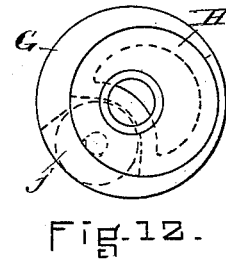
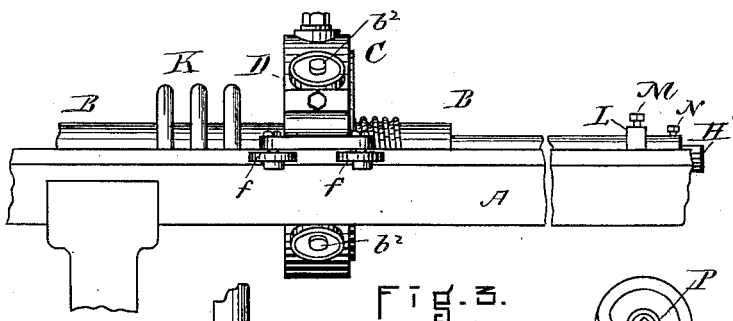
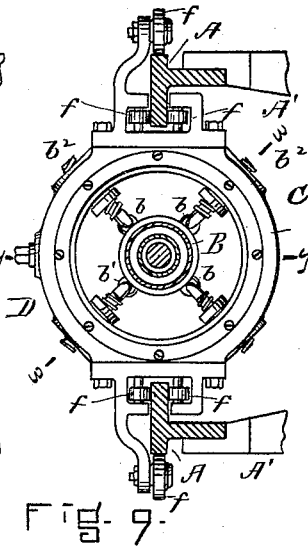
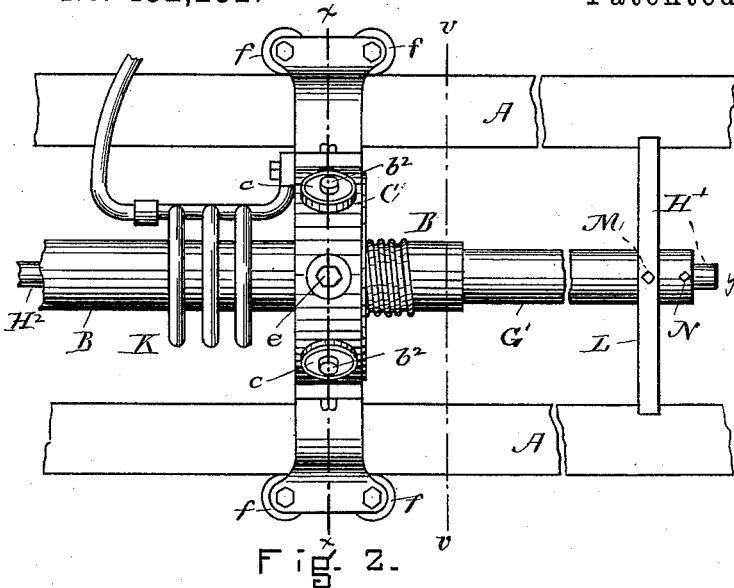

WITNESSES.

Hiram B. Andrews.
E. A. Child

INVENTOR.

John F. Fife
By George D. G. Coakley, Attorney.

(No Model.)

3 Sheets—Sheet 3.

J. F. FIFE.

MACHINE FOR CORRUGATING WROUGHT METAL TUBING.

No. 432,232.

Patented July 15, 1890.

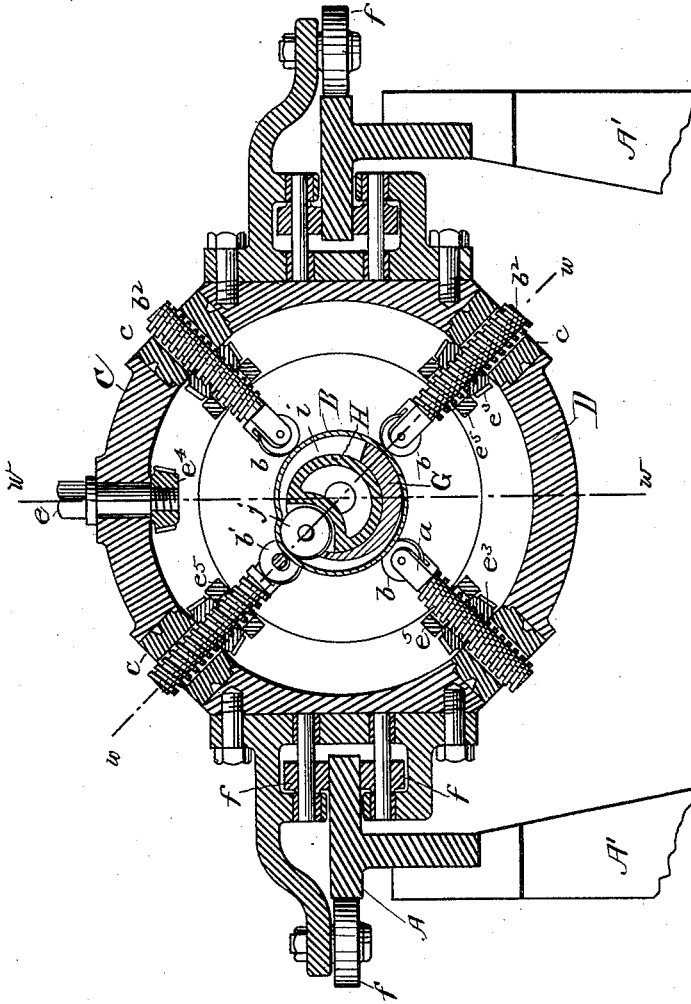

FIG. 10.

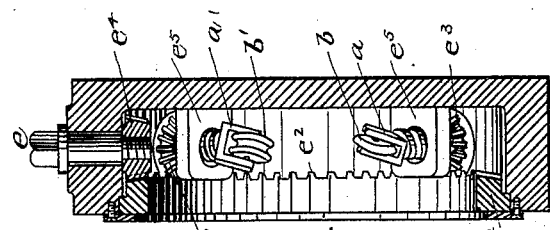

FIG. 15.

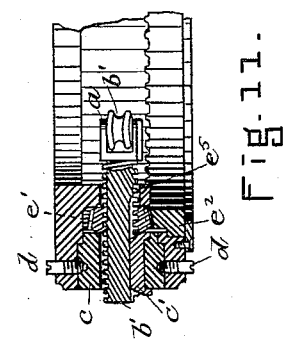

FIG. 11.

WITNESSES.
Hiram B. Andrews.
Ernest A. Guild.

INVENTOR.
John F. Fife
by George O. G. Conner
his attorney

UNITED STATES PATENT OFFICE.

JOHN F. FIFE, OF MEDFORD, ASSIGNOR, BY MESNE ASSIGNMENTS, TO THE WAINWRIGHT MANUFACTURING COMPANY OF MASSACHUSETTS, OF BOSTON, MASSACHUSETTS.

MACHINE FOR CORRUGATING WROUGHT-METAL TUBING.

SPECIFICATION forming part of Letters Patent No. 432,232, dated July 15, 1890.

Application filed April 1, 1889. Serial No. 305,632. (No model.)

To all whom it may concern:

Be it known that I, JOHN F. FIFE, a citizen of the United States, residing at Medford, in the county of Middlesex and State of Massachusetts, have invented a new and useful Improvement in Machines for Corrugating Wrought-Metal Tubes, of which the following is a specification.

The object of my invention is to produce a machine which shall indent a spiral groove of any length on the inner surface of a wrought-metal tube, and so produce a raised spiral groove on the outer surface of the tube which shall be of a somewhat greater diameter than the original diameter of the tube. For this purpose I have constructed a machine having a driving mechanism provided with a suitable chuck to hold and rotate the tube to be corrugated and a non-rotating tool-holder carrying a suitable tool to act within the tube, both to be used, if desired, with a die carrier or support passing over such part of the tube as is to be corrugated, all of which will be hereinafter more fully described.

In the drawings is shown a machine embodying my invention in the best form now known to me.

Figure 1 is a side elevation of such a machine, showing the driving mechanism and the tube in position undergoing the process of corrugation by means of the carriage and tool. Fig. 2 is a plan showing the carriage mounted upon the ways and a portion of the tube undergoing corrugation. Fig. 3 is a side elevation of the same. Fig. 4 is a detail of a portion of the section on line *ww* of Fig. 10. Fig. 5 is an elevation of the tool and tool-holder. Fig. 6 is an end view thereof. Figs. 7 and 8 show a spiral support, referred to below. Fig. 9 is a cross-section on line *vv* of Fig. 2. Fig. 10 is a section of the carriage on the line *xx* of Fig. 2, and Fig. 11 is a detail showing the ring-gear and means for adjusting the dies. Fig. 12 is an end view of the tool-holder with the tool withdrawn. Fig. 13 is a cross-section on line *xx* of Fig. 9.

A represents the ways of the machine. These ways are mounted on legs *A'*, and one end is supported by the frame *A²*, which car-

ries the driving mechanism. This driving mechanism consists of a cone-pulley *A³*, which connects by gearing with the hollow spindle *A⁴*, carrying a chuck *A⁵*, which is provided to hold the tube and impart to it a rotary motion. If the spindle is hollow, a very long tube, longer than the ways, can be corrugated in the machine, being fed through the spindle to the tool from time to time, as is desirable.

B is the tube. *C* is the carriage or die carrier, which is mounted on the ways *A* and runs thereon on friction-wheels *f*, so that it can be drawn along the ways with the least possible friction. The moving of the carriage is accomplished by the rotation of the tube. The rolls *b* bearing on the tube being arranged with their axes at an angle to the axis of the tube, the tube as it rotates travels in such a way against the rolls as to cause them to travel in a spiral line about the tube during the process of corrugation, and consequently to feed the carriage along the lathe-bed in a direction depending upon the direction of rotation of the tube. The carriage or die-carrier consists of an annular casting *D*, in which are secured four forks *a*, each supporting a roller *b b'*. The shank *b²* of each fork is threaded and is key-seated at *c'* in a splined bushing *c*, held in place by a set-screw *d*. (See Fig. 11.) Each threaded shank *b²* passes through a threaded pinion *e'*, which gears into a common ring-gear *e²*, to which motion is imparted by means of a square-headed gear-shank *e*, having on its inner end a pinion *e⁴*, which also gears into the ring-gear *e²*. The four rolls being set into the casting are adjusted toward or from its center by turning the shank *e*, which by means of its pinion *e⁴* moves the ring-gear *e²*, thereby turning the pinions *e'*, which being nuts and being held in place between the ear *e³* and the bushing *c* cause each shank *b²*, and consequently the roll mounted on the end of it, to be moved toward or from the center of the carriage, all the tools being by this means moved simultaneously, and consequently being caused to exert an equal pressure on all sides of the tube. The rolls must all be set

at an angle to the axis of the tube, so as to lie in a spiral around it. To set the rolls at a particular angle, the set-screws d are loosened and the bushing is turned the desired amount, carrying with it the shank b^2 , which is splined into it, as above referred to. The set-screws d are then made fast.

The inner tool is shown in detail in Figs. 5, 6, 10, and 12. It consists of a sleeve G , having an outer diameter equal to the inside diameter of the tube to be corrugated. This sleeve is made fast to a pipe G' . It is provided with a slot i , representing by its angle to the axis of the sleeve the pitch of the corrugation to be formed. The chamber within the sleeve G is cylindrical in shape, with its axis eccentric to the axis of the sleeve, and into this chamber fits the slug H , which is cylindrical in form. This slug H carries in one side of it the tool j , which is a roll mounted in bearings in said slug, so as to be free to rotate. It is set at the same angle to the slug as the slot i is to the axis of the sleeve, and these parts are so located with respect to each other that when in place the corrugating-roll j may be projected through the slot i in the sleeve, and so become effective to express or force outward the surface of the tube which is to be corrugated in the manner presently to be described.

It will be seen that to project the tool through the slot i or to withdraw or shield it so that it shall be no longer effective for purposes of corrugating it is only necessary to rotate the slug H from the position shown in Fig. 6 to the position shown in Fig. 12, the slot i extending sufficiently around the circumference of the sleeve for that purpose. This rotation is imparted to the slug by means of the rod or pipe H' , which is attached thereto and which may be turned by means of a wrench. One of the rolls b' should be corrugated, with two annular projections upon it in diameter like the rolls b , between which the metal can be pressed up from within by the tool j , and this die and the tool j act together to perfect the corrugation, the other rolls b being in the nature of friction-rolls, which cause the tube to remain centered and in proper position to be acted upon by the tool j and corrugated die. It is obvious that other means of centering the tube may be adopted.

The operation of a machine so constructed is as follows: The tube to be corrugated is made fast in the head-stock of the machine by means of the chuck in a manner well known to anyone skilled in the art. The sleeve G , inclosing the slug H , is inserted into the opposite end of the tube until the tool j reaches the point where the desired corrugation is to start. The pipe G' , on which the sleeve G is mounted is then clamped by means of the set-screw M in the sliding rest L , so that the pipe G' cannot revolve. The cross-piece L slides upon its ways A , so that the tool may be fed into the tube; but it prevents the tool from turning.

The rod or pipe H' is then rotated, so as to throw the tool out through the slot i in the sleeve G , and so indent the tube from the inside and cause the beginning of a corrugation, and is then set or held in place by means of the set-screw N , which passes through the pipe G' . The carriage C is then moved along the ways until the corrugated roll b' is immediately over the point referred to, where the corrugation is to start. The gear-shank e is then turned, so as to adjust the rolls to bear gently upon the outer surface of the tube, the adjustment being effected in the manner above described. The lathe is then set in motion, and a spiral corrugation will be pushed up or expressed from the surface of the tube by means of the constant pressure of the tool j against the tool b' , the pitch and form of the corrugation depending upon the angle of the tools j b' and the friction-rolls or dies b to the axis of the tube. The tools j b' and the friction rolls or dies b being set at an angle to the axis of the tube, the carriage and the tool-carrier are moved along the ways in a direction depending upon the direction of rotation of the tube and the angle at which these parts are set, as will be readily understood. When a sufficient length of tube has been corrugated, the screw N is loosened and the rod H' is turned back, so as to turn the slug in the sleeve and withdraw the tool j within the sleeve G . The tool-holder can then be removed from within the tube or can be moved to a different part of the tube and a fresh corrugation begun, as desired.

The rolls b b' may be used as dies to corrugate a tube by means of the mandrel shown in Figs. 7 and 8. This mandrel is a spiral spring secured to a long rod over which the tube is corrugated. The inner support is placed inside in position desired for the end of the corrugation, and the rod P , upon which this inner support is mounted, is clamped in the gripping-slide L , as above described. The tube is then rotated and the corrugations are made by passing the tube between the dies and the spiral spring or mandrel Q , which remains stationary, and when the desired amount of the tube has been corrugated the action of the machine is reversed. The tube is then unscrewed from off the spring, and as the spring yields slightly it is a very easy matter to remove the mandrel from the finished tube. In case the tube is hard and requires heat to make it more easily worked, I provide burners K , by means of which jets of flame are directed against portions of the tube which are to be corrugated just before they reach the corrugating-tool; and in order that the tool itself may not become overheated I prefer in this case to make the part H' a pipe instead of a solid rod and the slug H hollow, as indicated, and to provide a second pipe H^2 , leading from the opposite end of the slug, in order to keep up a circulation of water through these parts.

It is evident that the invention referred to

above may be embodied in a variety of ways and forms, the main feature of which, however, will be a tool located within the tube for the purpose of pressing the metal from the inside outward to form an externally-projecting ridge or corrugation, which shall have a greater diameter than the diameter of the tube in its original condition, means being provided for allowing substantially the entire length of the tube to pass in contact with the tool, so as to corrugate the entire length of the tube, the tool being so constructed that it can be introduced and withdrawn without difficulty. I believe, however, that the device above described, when used in connection with a lathe-bed and hollow spindle in the manner referred to, is the simplest and best for the purpose.

What I claim as my invention is—

1. In a machine for corrugating tubes, a carriage movably mounted upon ways, in combination with a corrugating-tool mounted in close proximity to said carriage upon a support and adapted to act upon the inner surface of the tube to be corrugated, said support being movably mounted upon said ways and said tool being adjustable toward and from the axis of its support, all substantially as and for the purposes set forth.

2. In a machine for corrugating wrought-metal tubes, a carriage movably mounted upon ways and provided with one or more rolls located to bear upon the outer surface of the tube to be corrugated, and a corrugating-tool mounted in close proximity to one of said rolls upon a support movably mounted upon said ways, said tool being adjustable toward and from the axis of its support and adapted to bear upon and corrugate the inner surface of said tube, all substantially as and for the purposes set forth.

3. In a machine for corrugating wrought-metal tubes, a corrugating-tool and tool-carrier mounted upon suitable ways, said tool-carrier consisting of a cylindrical slug located eccentrically within a sleeve fitted about said slug, the outer diameter of said sleeve corresponding with the inner diameter of the tube to be corrugated, said sleeve being provided with a slot at an angle to its axis and said tool being embedded in the slug with its bearing-surface in line with and capable of pro-

jection into said slot, said slug and said sleeve being provided with suitable operating mechanism, whereby they may be brought into operating relation to each other and the tube to be corrugated, all substantially as set forth.

4. In a machine for corrugating wrought-metal tubes, in combination with a carriage carrying one or more rolls, a corrugating-tool and tool-carrier consisting of a cylindrical slug located eccentrically within a sleeve fitted about said slug, the outer diameter of said sleeve corresponding with the inner diameter of the tube to be corrugated, said sleeve being provided with a slot at an angle to its axis and said tool being embedded in the slug with its bearing-surface in line with and capable of projection into said slot, said slug and said sleeve being provided with suitable operating mechanism whereby they may be brought into operating relation to each other and the tube to be corrugated, all substantially as set forth.

5. In a machine for corrugating wrought-metal tubes, a tool mounted upon a hollow slug or bearing and the pipes H^2 , connected with said slug, whereby a circulation of water may be kept up through said slug and pipes, in combination with a heating device located in close proximity to said tool, all as set forth.

6. In a machine for corrugating wrought-metal tubes, in combination with a die-carrier, the mandrel above described, consisting of a rod provided with a spiral spring mounted thereon, all as set forth.

7. The carriage above described, consisting of a circular head and a ring-gear mounted therein, one or more threaded shanks, each provided at one end with a roll and at its other end being keyed in a bushing capable of rotation in said carriage, said shank passing through a pinion geared in said ring-gear, all in combination with mechanism of substantially the kind described, whereby said ring-gear may be moved, all as set forth.

In testimony whereof I have hereunto subscribed my name this 29th day of March, A. D. 1889.

JOHN F. FIFE.

Witnesses:

GEORGE O. G. COALE,
EVA A. GUILD.